

ESTATE SERIES: Assembly Instruction For Front Mount, Full Post Option

APPLICABLE TO: Richmond, Baton Rouge, Altair, Wilkes, Oak Hill & Delta

Tools Needed (not provided)

- 7/16" socket or adjustable wrench (7/16" socket is preferable)
- Phillips screw driver
- No Drilling is required (all necessary mounting holes have been pre-drilled at factory)
- All necessary hardware is provided (i.e. stainless steel nuts & bolts)



1

With Estate series post securely mounted into the ground, locate the (4) Stainless steel threaded inserts that are already set into the post. This is where the Estate Series bracket will mount to.

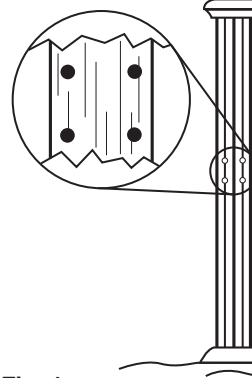

Fig. 1

2

Fasten the "Estate Bracket" to the front of the Estate series post utilizing the (4) 3/4" x 1/4-20 bolts, and the preinstalled stainless steel inserts.

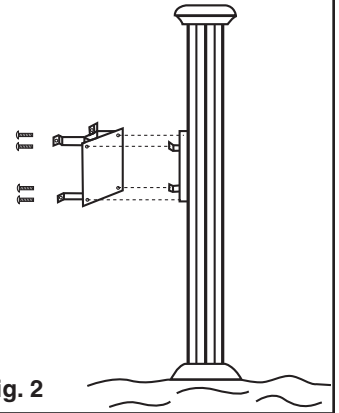
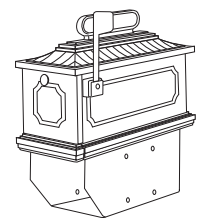
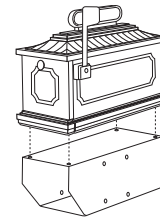

Fig. 2

3

Attach the mailbox to the newspaper tube using the (4) 1/2" x 1/4-20 bolts and (4) nylock nuts. If your mailbox style does not use newspaper tubes, skip ahead to the next step.



4

Bring the complete mailbox/tube unit to the front of the post and line up the predrilled holes in the back of the newspaper tube with the (4) holes on the estate bracket. Fasten to the estate bracket using the (4) 3/4" x 1/4-20 bolts and (2) nylock nuts.

(If your mailbox does not use a newspaper tube, the estate bracket will fasten directly to the back of the mailbox using (4) predrilled holes)

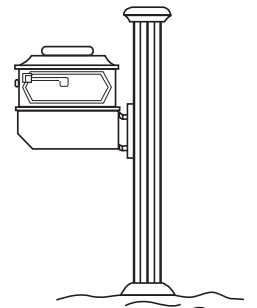
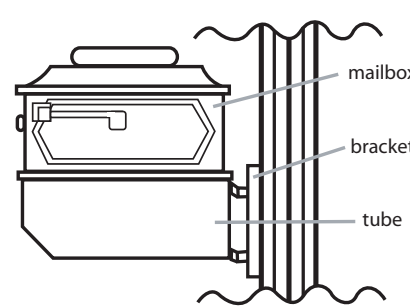

5

5-A.) Attach the address scroll to the bottom of the newspaper tube using the provided 3/4" x 1/4-20 bolt and (1) nylock nut. The newspaper tube has a pre-drilled hole that is slotted for easy adjustment for height of the mailbox on the post.

(The Richmond & the Altair do not use an address scroll)
(If your mailbox does not use a newspaper tube, the scroll will attach directly to the bottom of the mailbox.)

5-B.) Use the remaining (1) 3/4" x 1/4-20 bolt to attach the bottom of the address scroll directly to the post. A threaded stainless steel insert is already in the post for this purpose.

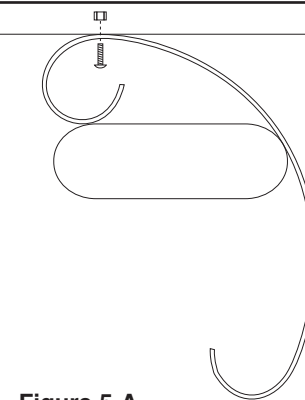

Figure 5-A

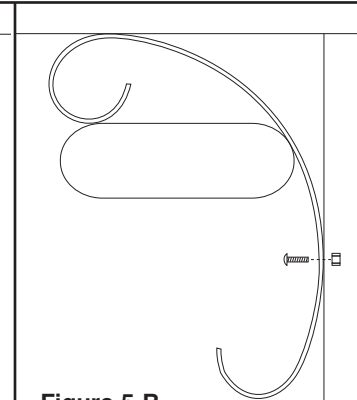

Figure 5-B